

A. E. BROWN.
DRIVER FOR LATHES OR PLANING MACHINES.

No. 453,616.

Patented June 9, 1891.

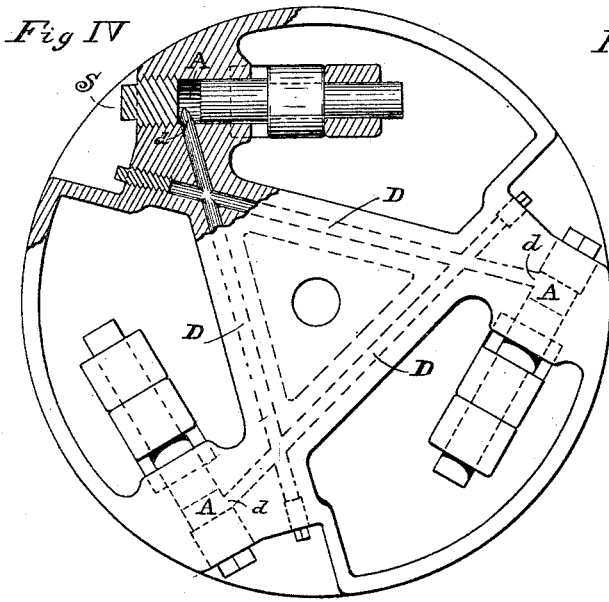

Fig V

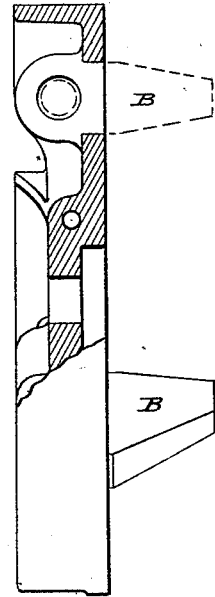

Fig III

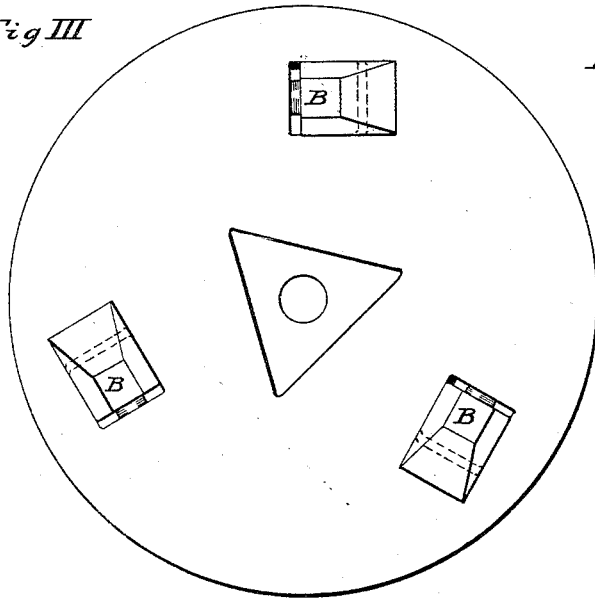

Fig I

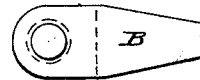
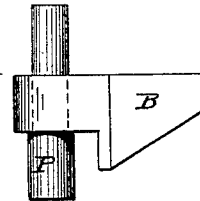

Fig II



Witnesses
E. T. Scovill
H. F. Balwin

Inventor
Alexander E. Brown
by George C. Wing
his Attorney

A. E. BROWN.

DRIVER FOR LATHES OR PLANING MACHINES.

No. 453,616.

Patented June 9, 1891.

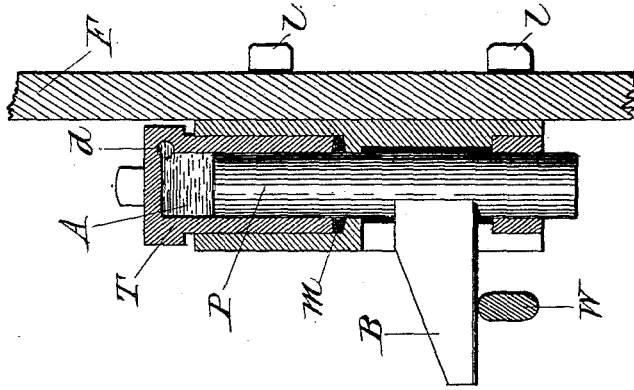

Fig. 6.

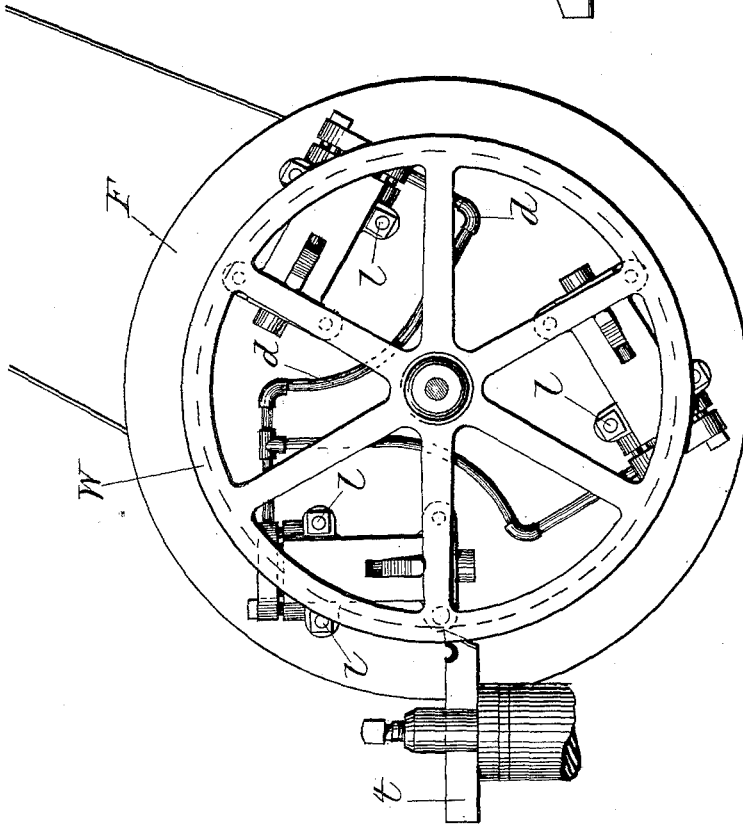

Fig. 7.

WITNESSES,

J. M. Dyer
C. A. Adams, Jr.

INVENTOR.

Alexander E. Brown
by *George W. Wing*
his ATTORNEY.

(No Model.)

4 Sheets—Sheet 3.

A. E. BROWN.

DRIVER FOR LATHES OR PLANING MACHINES.

No. 453,616.

Patented June 9, 1891.

Fig. VIII

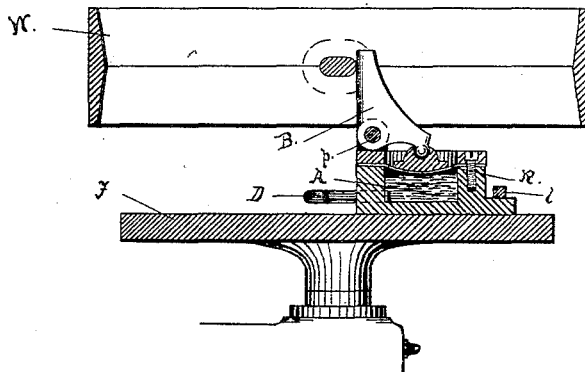
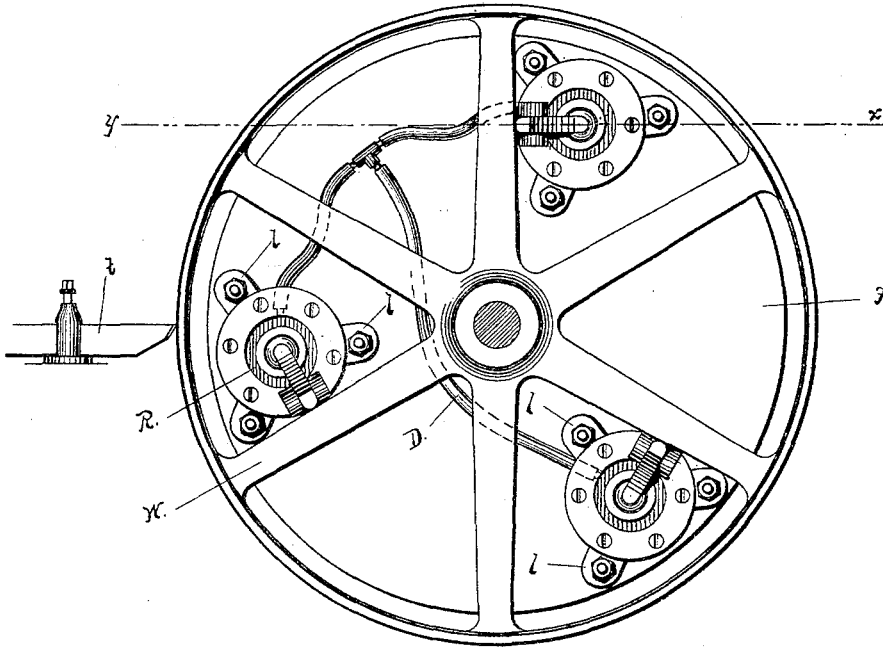

Fig. IX.

WITNESSES:

J. M. Dyson
C. A. Adams Jr.

INVENTOR.

Alexander E. Brown
 by *George B. Wing*
 his ATTORNEY.

A. E. BROWN.
DRIVER FOR LATHES OR PLANING MACHINES.

No. 453,616.

Patented June 9, 1891.

Fig. XI.

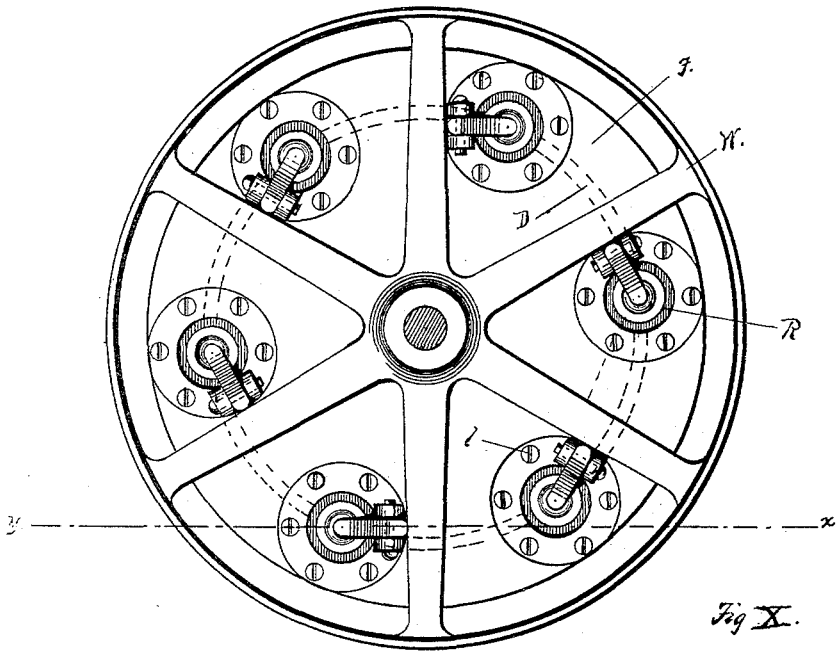
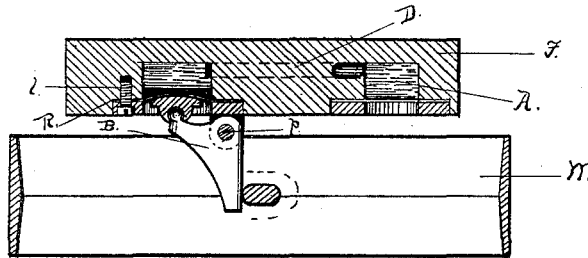

Fig. X.

WITNESSES.

J. M. [Signature]
C. A. Adams Jr.

INVENTOR.

Alexander E. Brown
by *George C. Wing*
his ATTORNEY.

UNITED STATES PATENT OFFICE.

ALEXANDER E. BROWN, OF CLEVELAND, OHIO.

DRIVER FOR LATHES OR PLANING-MACHINES.

SPECIFICATION forming part of Letters Patent No. 453,616, dated June 9, 1891.

Application filed March 23, 1889. Serial No. 304,559. (No model.)

To all whom it may concern:

Be it known that I, ALEXANDER E. BROWN, a citizen of the United States, residing at Cleveland, in the county of Cuyahoga and State of Ohio, have invented a new and useful Machine, of which the following is a specification.

My invention relates to that class of shop tools and appliances by which wheels, sheaves, pulleys, and similar work, when placed for treatment upon the plate or table of a lathe or planer, are afforded the requisite support against the strain of the cutting-tool; and the object of my invention may be said to be to provide a series of drivers adapted for use in situations and for the purposes above indicated, which drivers, first, will simultaneously arrange themselves in the same degree of contact with the piece to be operated upon relatively to each other as soon as such piece is brought into bearing with the several drivers, and, second, will maintain such relative degree of contact, however often or considerably the resistance at one or more of the driving-points may vary.

The only driver in use in the shops or, so far as I am aware, which has yet been devised besides mine is essentially an arm or bar which either pierces the base-plate or table or travels in the ordinary T-slots therein, and is designed to be made to meet the work under treatment at various points after successive independent manipulations, and to be then and there firmly secured in position. The use of these drivers, however, is consequently attended with certain well-recognized disadvantages, of which, perhaps, the principal disadvantage is the inability to secure such a resultant bearing among all the drivers employed as will equally and certainly divide up the resistance incurred at the particular point where a cut is being made. In the prevailing method of securing work upon a face-plate the first driver is fastened upon or through said plate, and the work is then turned about on the mandrels until pressed closely against the same. The operator thereupon locates the second and additional drivers at other parts of the plate and into such bearing relations as appear to him at the moment to be as nearly as practicable identical with the contact or bearing degree of the first driver.

The preliminary stages of the operation of setting these drivers are therefore largely dependent, so far as satisfactory results are concerned, upon the skillfulness, care, and special experience of the individual operator. Nevertheless, however capable the latter may be, there are certain to occur during his necessary movements in testing and securing the second and successive drivers sufficient jars, variations, or relaxations from the original bearings to develop in the ultimate bearings of each separate driver, and, in spite of every precaution, a wide difference in the degree of contact sought and that actually attained. The evident result of such inequality in driver contact is that the resistance to the cutting-tool, instead of being taken up at the point of application and evenly distributed throughout all points of support, is thrown upon but two or more of the drivers and the strain unduly concentrated upon a few instead of the many points of the work under treatment. Among the well-known consequences of the above-described mode of fastening work are the frequent and undesirable "chatter" of the same under the tool, and, particularly where the reduction of frail pieces is attempted, either a wasteful percentage of breakage or such a forced diminution of speed or cut as equally enhances the general cost of turning and reducing the articles involved.

It is the design of the several constructions, shown and described herein as special forms by which I utilize my invention, to avoid in the department to which they relate all the defects and disadvantages above referred to, and at the same time to furnish appliances which present corresponding merits of exceptional importance and value. I attain these objects by the devices illustrated in the accompanying drawings, wherein appear several forms embodying my invention or constituting modifications thereof.

Figure I is a face or front view of a driving-arm adapted to be carried and actuated by a plunger device hereinafter specified. Fig. II is a side view of the same driving-arm mounted upon its plunger. Fig. III is a side view of the front face of a specially-constructed chuck or plate, through which a set or series of three of my driving-arms project. Fig. IV is the reverse view of the same plate,

showing through broken or dotted lines the essential connections of such a series and a detailed view of the novel operating parts thereof. Fig. V is a semi-transverse vertical section of a plate or body especially constructed as a convenient mode of presenting a set of drivers in a compact though somewhat restricted form. Fig. VI is a transverse vertical section in detail of a modification of my invention adapted to be bolted or otherwise affixed to an ordinary chuck or face-plate in sets of two or more. Any especially-constructed plate, as appears in the preceding figures, is not required in the use of the device here shown. Fig. VII represents the device last described when affixed in a full operative series to a face-plate, with the component members thereof connected between themselves by independent tubing *d d*. Fig. VIII illustrates a further adaptation of my invention in the form of a series of separately-constructed drivers actuated by and upon a diaphragm, (instead of plungers, as in Figs. I to VII,) in the manner to be more particularly explained hereinafter. In this series separate and independent tubular connections *D D* are employed between the several driver-carriages and their chambers *A A*, and, like the series shown in Fig. VII, the device is adapted to be fixed at will to an ordinary face-plate or working-table. Fig. IX is a detailed transverse vertical section of one of the drivers shown in Fig. VIII through the line *xy* thereof. Fig. X is an especially-constructed form wherein drivers of the character shown in Figs. VIII and IX are permanently located, and ducts for intercommunication with the several chambers *A A* beneath said drivers are likewise fixed, and are integral with said form, which is without peculiar features in other respects. Fig. XI is a transverse vertical section through said form, Fig. X, through the line *y x*.

By the variety of the forms appearing in the several drawings herewith it will be evident that I do not intend to limit my invention, broadly speaking, to the precise designs and details therein depicted nor to any structures wherein, for instance, the intervals between the drivers have any fixed limit or proportions. The channels between the several chambers are neither restricted as to number, dimensions, points of intercommunication, nor as to any other similar detail or arrangement of either construction or connection.

Pointing out now more particularly the several features of the devices shown in the accompanying drawings, it will be noted that *B B* in every instance designates the driving-arm, which in actual operation is to bear directly against either the work under treatment or the dog affixed thereto. In Figs. I to VII the driving-arms *B B* are mounted upon the plungers *P P*, which latter are adapted to reciprocate within the chambers *A A* and at the same time to sufficiently close the said chambers against the escape of the oil or other

fluid within. A form of construction is readily conceived wherein the outer extremities of said plungers either themselves constitute the drivers by bearing directly and immediately upon the work in the line of their centers, or where said plungers, instead of being mounted by, are so bent as to perform the functions of, the driving-arms *B B*, thereby dispensing with the latter parts either entirely or as separate details. In Figs. I to V said plungers carry the driving-arms *B B* and are preferably extended to enter an exterior guide and thereby insure a somewhat increased firmness of action.

In the devices shown in the drawings from Figs. VIII to XI, inclusive, the office of the plungers *P P* is performed by a flexible or elastic diaphragm of any suitable material. Said diaphragm closes the chambers *A A* and is actuated by and upon the driving-arm *B B*. In this construction the latter may take any convenient form—as that, for instance, shown in the said drawings, Figs. VIII to XI—and may be pivoted or otherwise adapted to turn about a fixed point, as at *p*, when subjected to resistance at its either extremity.

The several chambers *A A* are connected by intercommunicating channels or ducts *D D*, which terminate, respectively, at points within the said chambers *A A*.

In the devices shown and described a reciprocating plug to regulate the space for the containing fluid and to admit the same may be located at any convenient and suitable point. In Fig. IV such a plug is shown to enter one of the said chambers at *S*. In the several devices illustrated in the drawings herein from Figs. I to V, inclusive, the said intercommunicating channels *D D*, as well as the chambers *A A*, into which the plungers *P P* there shown reciprocate, are integral with a face-plate or chuck, which admits the said driving-arms *B B* to pass through orifices in said plate and appear at points on the reverse face thereof, as in Fig. III, and there serve as bearings for the spokes of a wheel, the dogs on a shaft, or for other work to be reduced by the cutting-tool. In such construction the said orifices are of course sufficiently ample to permit the arms *B B* to play therein according as their respective plungers advance or retreat. The devices shown in Figs. VI and VII, on the other hand, are especially characterized by the fact that the chambers into which the said plungers reciprocate are within and a part of as many cylindrically-hollow plunger-carriages, each of which is wholly separate and distinct from the other plunger-carriages of the series, save in the feature of the interconnecting ducts. The latter, as in the devices shown, may themselves be entirely independent of any special frame or integral construction.

The constructions just described, as well as those shown in Figs. VIII and IX, are provided with bolts or other facilities for affix-

ing them at any points on the surfaces of the plate F desired.

A preferable detail of construction appears in Fig. VI, where, to complete the chamber 5 A, a concentric tubular cap T enters the original chamber-cavity and into bearing upon the packing m.

Figs. VIII and IX exhibit further modifications of my invention and of its specific forms 10 last above described. The distinctive feature of these constructions as compared with those shown in Figs. VI and VII is the substitution for the cylindrical plungers P P of a metallic or other suitable vibratory diaphragm. 15 Said diaphragm is firmly seated across and so as to securely close the outer orifice of the said chamber A, which orifice in the forms shown is through the upper horizontal surface of the plunger-carriage, instead of in a 20 vertical face of the same, as in the devices in Figs. VI and VII. A series of three of said plunger-carriages is represented in the drawings, and as supporting a wheel W, against which the cutting-tool A is shown as applied 25 in the usual manner. It is, however, of course apparent that in none of the devices hereinbefore shown and described is the precise number of drivers in a given series material, but that such particulars may be governed 30 entirely by the choice of individual operators.

To operate the said devices the intercommunicating channels D D and the chambers A A are filled with oil, water, glycerine, or any other suitable liquid or mobile fluid. 35 When the special forms are employed independent of a connecting frame or chuck such as is shown in Figs. III, IV, V, and X, the plunger-carriages are so located that the face of the driving-arms upon their plungers are 40 each in operative proximity to the work to be handled at whatsoever points resistance is desired. In such positions said plunger-carriages are firmly bolted or otherwise secured to the face-plate or working-table. Of course the 45 exterior form and surface of said carriages are such as to conveniently admit of their resting upon and being firmly fixed to the front face of the said plate, as described, or so that, if preferred, instead of in the positions above designated the said appliances may be located 50 upon the reverse of the base or the face-plate, to allow the driving-arms B B to project through suitable orifices therein, in the manner that the driving-arms are shown to project through the especially-constructed false 55 face-plate of the drawings in Fig. III. The

work to be treated having been forced closely upon the drivers by the resistance of the cutting-tool upon the work itself, it is evident that the plungers of said drivers, each now 60 pressing within its chamber A against a common and unyielding fluid, have simultaneously and instantly adjusted themselves to such position that the said driving-arms have the same degree of bearing contact one as the 65 other. It is further apparent that, this uniform initial degree of bearing contact having thus been secured, there will be no subsequent yielding at any of the bearings; but whatever strain is cast upon any one in the 70 course of the treatment to which the supported work is subjected, will, by means of the common and unelastic fluid through the ducts D D and the chambers A A, be instantaneously communicated to and shared by all the 75 others.

What I claim as new, and desire to secure by Letters Patent, is—

1. In an equalizing driving apparatus for the purpose specified, the combination of a 80 series of two or more drivers or driving-arms, a suitable body, frame or frames supporting the same, and a confined fluid-body, against the common pressure of which the said drivers or driving-arms act and are resisted. 85

2. In an equalizing driving apparatus for the purpose specified, the combination of a series of two or more plungers or pistons acting as or supporting drivers or driving-arms, a suitable plate or frame (adapted to be se- 90 cured to a lathe, boring-mill, or other machine-tool) supporting said plungers, and a fluid-body within a common chamber or a series of intercommunicating chambers, against the common pressure of which the said plungers 95 act and are resisted.

3. In an equalizing driving apparatus for the purpose specified, the combination of a series of two or more plungers or pistons acting as or supporting drivers or driving-arms, two 100 or more separate bodies or plates, (adapted to be secured to the face-plate or table of a lathe, boring-mill, or other machine-tool,) each containing or supporting one of said plungers, and a fluid-body confined in intercommuni- 105 cating chambers by said plungers, against the common pressure of which the said driving-plungers act and are resisted.

ALEX. E. BROWN.

Witnesses:

GEORGE C. WING,
E. T. SCOVILLE.